

adaptiv
DIC

myWall.

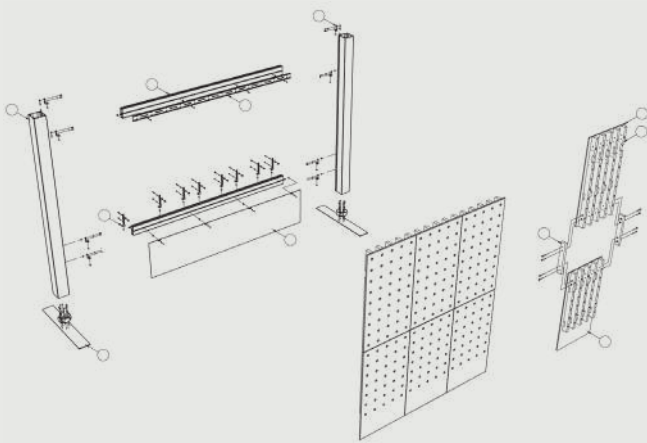

Form and Function, Every Time.



EXHIBIT

myWall.

MODULAR DISPLAY SYSTEM

AdaptivDC is the proud provider of the (Thinkterior) myWall Inline Display System, a breakthrough in display hardware, and provides design, fabrication and installation to business clients across the United States.

Most versatile exhibit system on the market in the United States.

The myWall Inline Display System changes the game when it comes to versatile, easy-to-assemble infrastructure for exhibits, either permanent, temporary, and/or mobile. A major advantage of myWall over more dated display structures, myWall can be set up any way you want and it's load bearing (a key point: the price of load bearing booths can be prohibitively costly). While the public-facing walls are perfect for product display, the back side of the wall can be used for storage, as a work space, and even as a place to hang your coat!

The flexibility resulting from this design means that exhibitors can modify their on-site mission from event to event, even throughout the course of the day. Ready to switch from selling product to providing a meeting space? Easy to do. Custom add-ons, including our line of learning tools, can also make myWall the perfect choice.

The myWall Inline Display System is an out-of-the-box exhibition solution that allows you to customize your booth according to the needs of the day. It's load bearing (pile on the product!); easy to assemble/disassemble; and its' high-quality design and construction give you the ability to promote your products to the best effect again and again. The wide range of available accessories allow additions and modifications of your booth over time, and are very competitively priced.

Form and Function, Every Time.



Product load bearing system

myWall.

Overall system is customizable into many other structure shapes and configurations.

Key Point!

myWall's patented locking pin system allows users to use both the front or back of the wall panels for product display, storage, and increased marketing surface.

Thanks to the locking pins, myWall becomes an ultra safe display surface capable of handling all the equipment and product you want to throw at it.

ABOUT MYWALL

The myWall Inline Display System is the perfect piece of mobile infrastructure for brands looking to make their product exhibits stand out. Rooted in design cues derived from both Scandinavian and Japanese design, the high-quality myWall system is designed to provide vendors with a mobile, modular and customizable exhibition display system ready to be used time and again. It's extremely sturdy and load bearing--perfect for product display no matter the weight. Finally, the freedom to display your brand and products in a way that will stand out to every crowd, every time.

KEY FEATURES

- High-end design
- Easily customizable, wide variety of accessories
- Sturdily crafted
- Increase ROI, use again and again
- Easy to assemble, minimal tools
- Don't be generic, stand out
- Cost efficient compared to fully customized booths
- Complete customization with modular plug-and-play shelving
- Durable, environmentally friendly hardwood panels (recycled aluminum & renewable rubber wood)
- Modular savings: start simple and build up on a budget
- Structural support for products, displays, TV's, etc.
- Load bearing system for heavy object display



* Custom items available upon request

myWall.

SAMPLE USES



20X20 Island Cube



20X20 Island Cube



10X20



Back of wall storage



20X20 Island Cube



10x20

myWall.

EXHIBIT / DISPLAY STRUCTURES

Overall system is customizable into many other structure shapes and configurations.

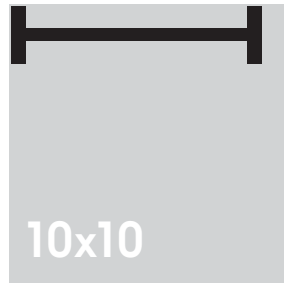
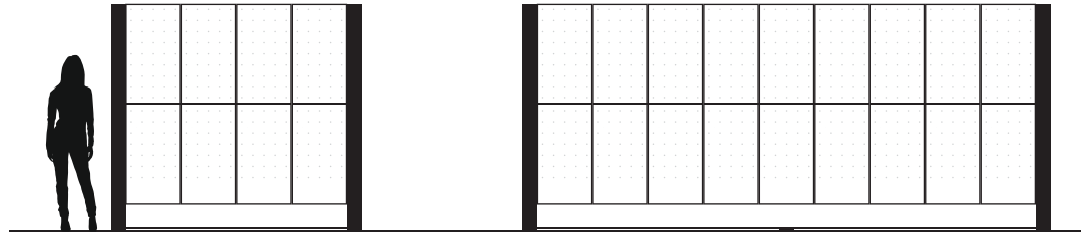

10x10 space
Back wall

Dims:
2743mm W (9')
2438mm H (8')

Panels:
4 mywall

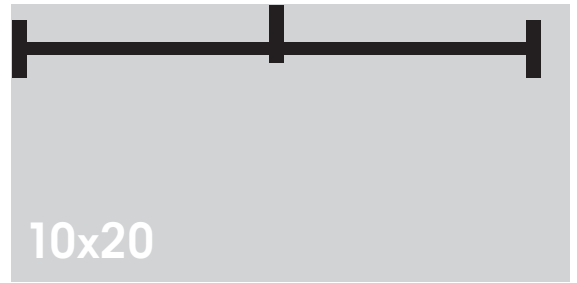

10x20 space
Back wall

Dims:
5791mm W (19')
2438mm H (8')

Panels:
9 mywall

Island cube provides storage on interior surfaces or for use as additional meeting space.

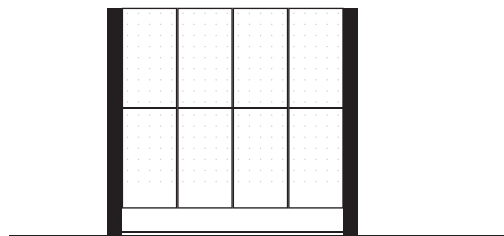

20x20 space
Island System

Dims:
2743mm W (9')
2438mm H (8')

Panels:
16 mywall

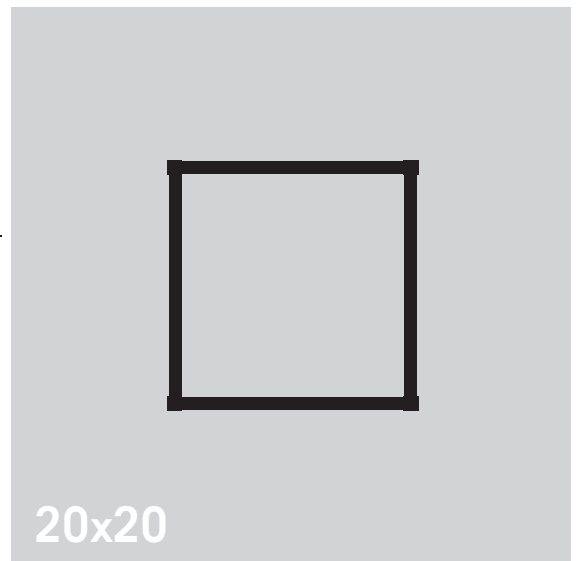

20x20

myWall.

HOW THE SYSTEM WORKS

myWall locking pin system

This patent pending locking pin system allows users to use both the front or the back of the wall panels for product display, storage, and marketing surface.

With the use of locking pins, the structure becomes a safe display surface for multiple objects on display.

Pins work on both the front and back of the wall system, providing extra storage behind your wall.

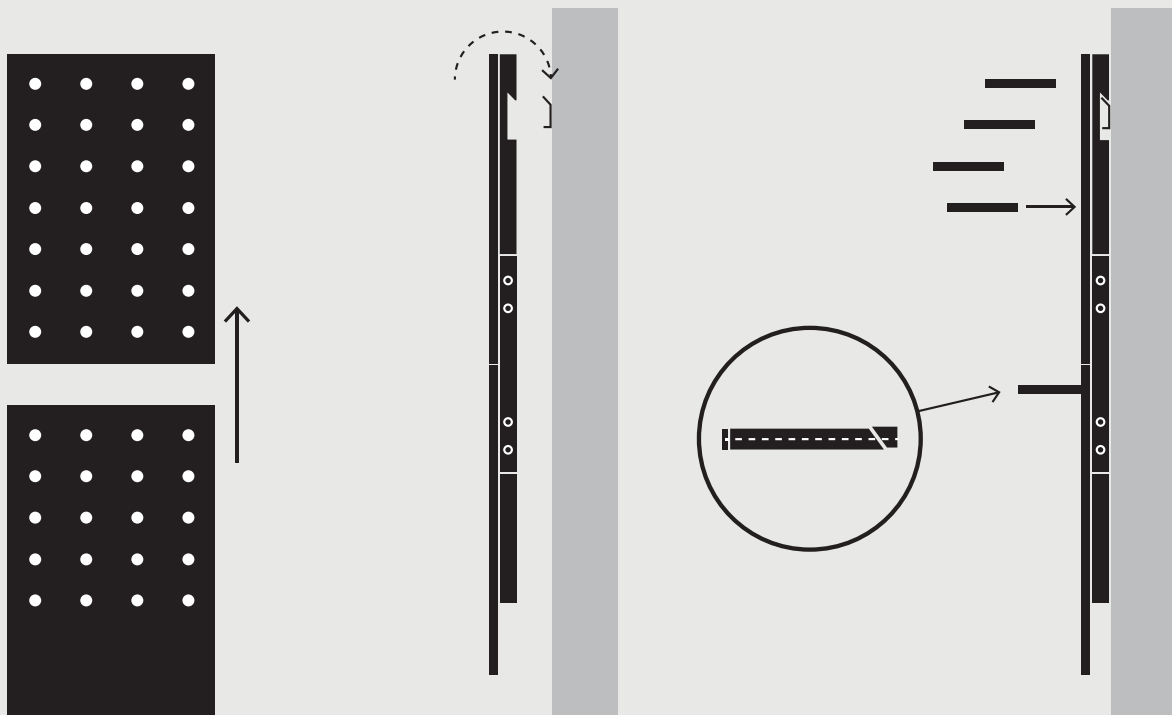

myWall.

PANEL SPECIFICATIONS

myWall panels are produced in 2 colors - natural or white wash.

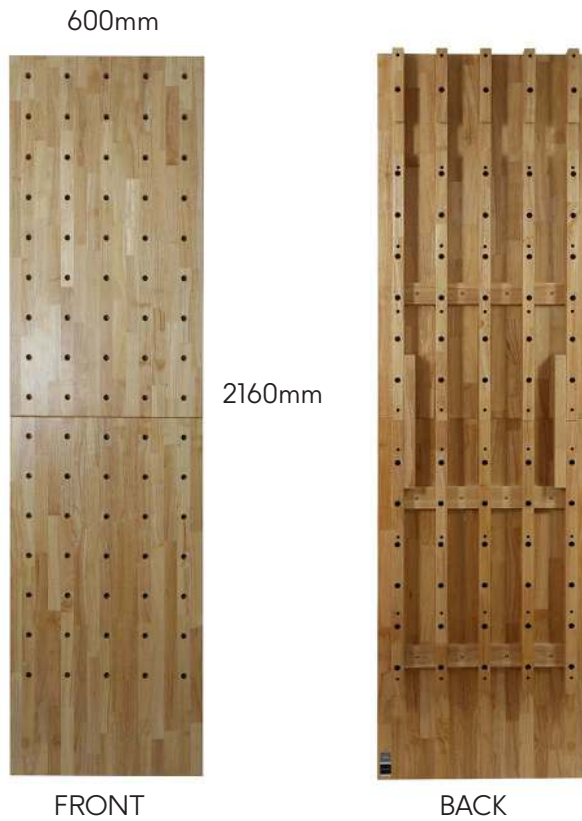

GENERAL PRODUCT SPECS:

Height: 2160mm

Width: 600mm

Depth: 72mm

Pin Hole Diameter: 16.3mm

Pin Hole Depth: 38mm

Weight: 23 kilogram

2 color options



Back of myWall detail



French cleat section



Locking Pin



Product Items List

- | | |
|----|------------------------------|
| 1 | Vertical Tower Support |
| 2 | Support Base Plate |
| 3 | Horizontal Support Beam |
| 4 | French Cleat Bracket |
| 5 | Lower Wall Locking Plate |
| 6 | Skirt |
| 7 | Horizontal Support Bracket |
| 8 | myWall upper panel |
| 9 | myWall lower panel |
| 10 | myWall vertical support |
| 11 | myWall upper/lower connector |

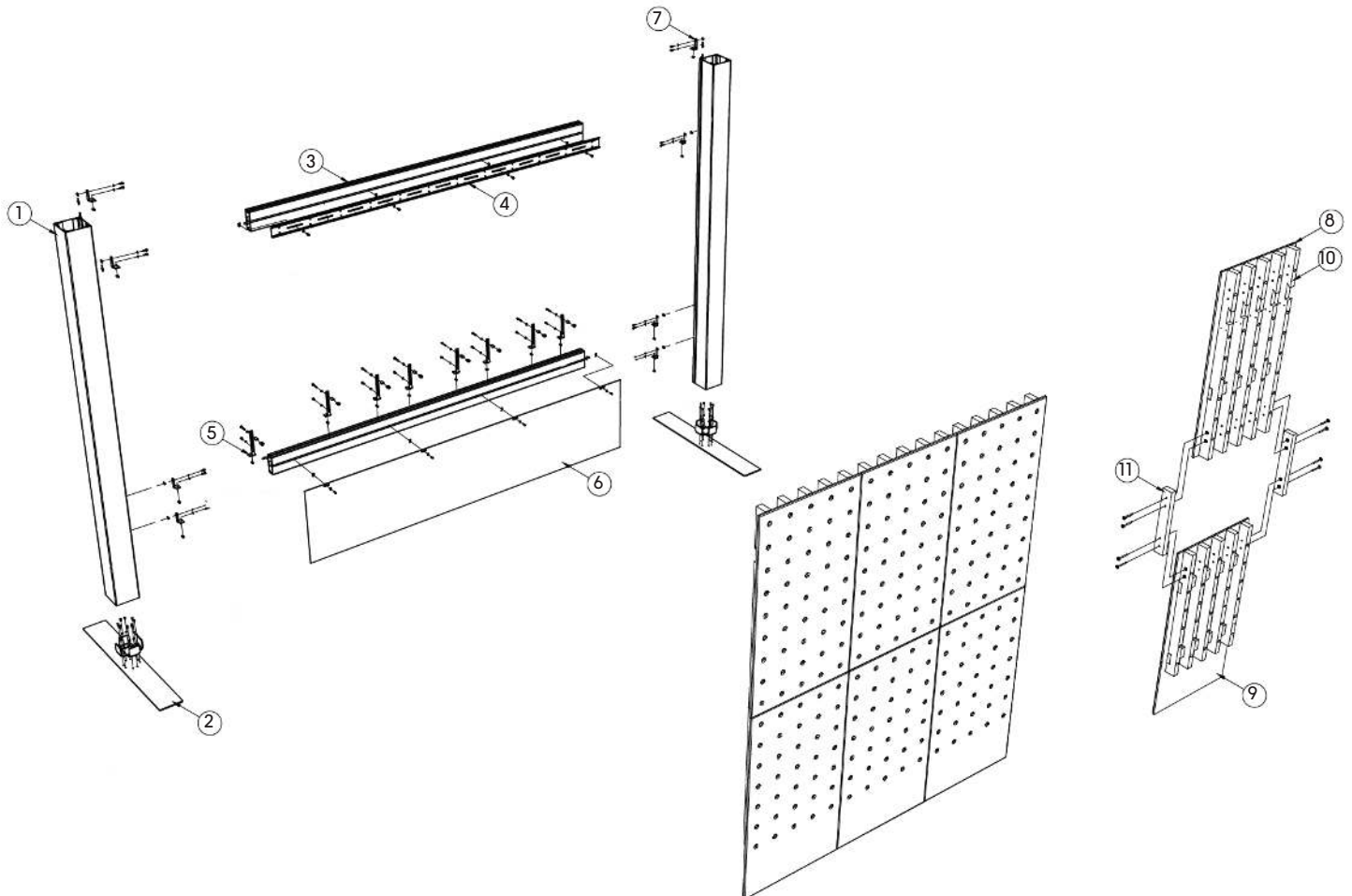

ITEMS

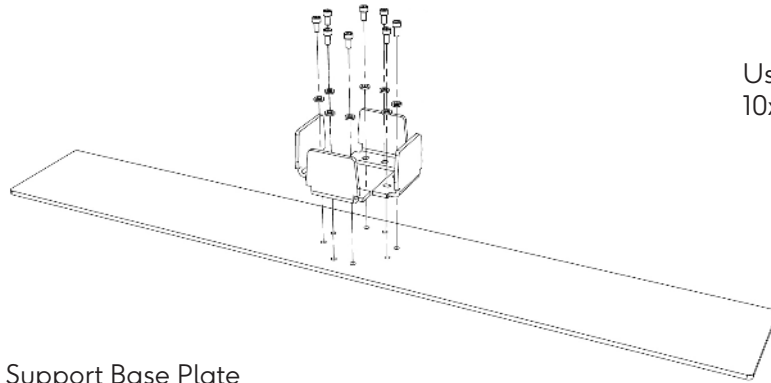

Used as base for 10x10 and 10x20 inline wall units

2

Support Base Plate

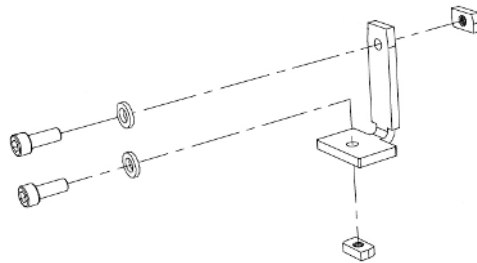

Used for locking horizontal supports onto vertical tower supports.

7

Horizontal Support Bracket

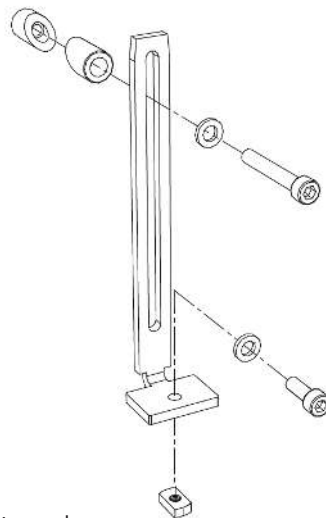

Used for locking lower section of myWall panels into the lower horizontal support beam

5

Lower wall locking plate

ITEMS

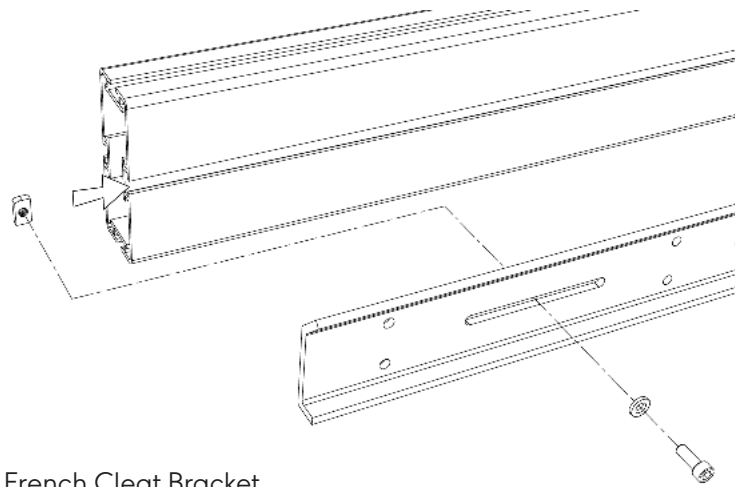

Cleat is used to hold myWall panels and is mounted directly to upper horizontal support beam.

4

French Cleat Bracket

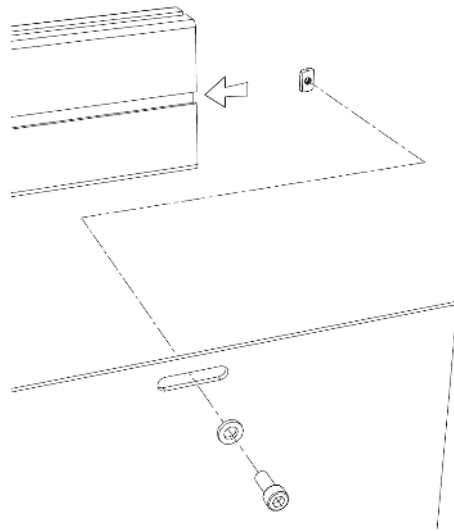

Lower skirt mounts directly to lower horizontal support beam.

6

Skirt

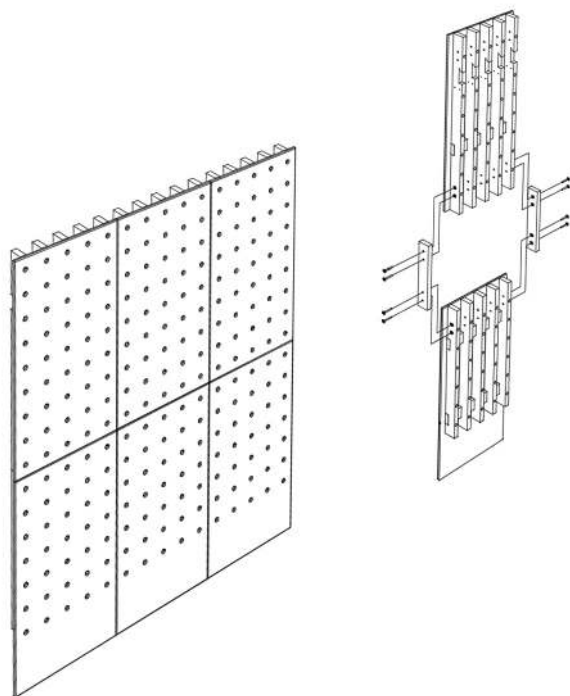

myWall panels attach as an upper and lower section, that then hang onto upper horizontal support beam with the use of the french cleat.

8/9

myWall Panels (upper / lower sections)

RENEWABLE RESOURCES

The myWall system uses rubber wood, a renewable and sustainable byproduct of the latex industry.

Reduce: We work with our manufacturing partners to ensure we are leaving as small a carbon footprint as possible.

Re-use: Our products are durable and designed to last, cutting down the need to discard our products and purchase new ones.

Recycle: Our products and components use recyclable materials.



myWall is a registered trademark and patented design of Thinkterior Studio Pte Ltd, Singapore.

All Rights Reserved.
©2017



AdaptivDC
42395 Ryan Road
Suite 112 / PMB 212
Ashburn, VA 20148

800. 693. 0068
hello@adaptivdc.com
adaptivdc.com